

Key Features:

High Accuracy

- ± 2.0 ns pixel jitter
- 47 dB S/N ratio
- 16 or 24 bits color
- 8 bits monochrome
- Programmable brightness, contrast, hue, and saturation

High Performance

- Real-time video streaming with AVI file creation
- 120+ MB/second sustained PCI bus transfers
- Simultaneous real-time transfer to memory and display
- Independent, dual video data paths

Video

- 4 standard video inputs
- Composite color
- S-Video
- NTSC, PAL, RS-170, CCIR
- VCR stabilization

Controls

- Dedicated trigger input
- Camera power

Software

- Windows 2000, 98, 95, and NT support
- Software compatible across I-Series and HI*DEF family
- IDEA SDK
- Common Vision Blox, Image-Pro Plus, Optimas, and TWAIN drivers
- Example programs with source code

Applications:

- Medical Imaging
- Scientific Imaging
- Machine Vision

Not your average color frame grabber. Unlike other color video frame grabbers, I-Color™ by Foresight Imaging is not based upon “reference designs” from the decoder chip manufacturers. Instead, I-Color is a member of the high accuracy, high performance I-Series™ of frame grabbers and video streamers. I-Color is based upon the I-Series architecture, guaranteeing the same high speed PCI bus transfers and video streaming as well as the superior image accuracy that Foresight Imaging has built its reputation upon to service demanding applications in medical imaging, scientific imaging, and machine vision.

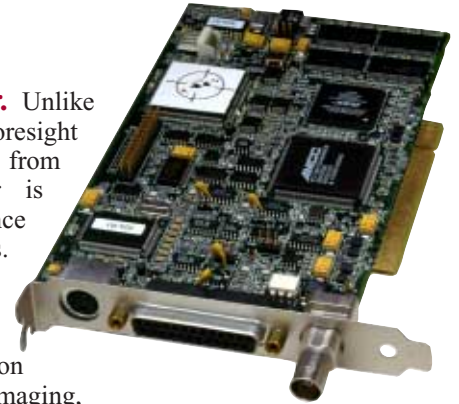

Accuracy

I-Color delivers the diagnostic-quality and inspection-quality images that demanding customers in medical imaging and metrology applications require. Low pixel jitter of ± 2.0 ns, superior analog design, and a 47 dB S/N ratio provide the accuracy and precision needed in high performance applications. Color video digitization is performed at either 16 or 24 bits, while monochrome acquisitions are 8 bits. Color formats include YUV 4:2:2 and RGB 8:8:8.

Performance

As a member of the I-Series of frame grabbers and video streamers, I-Color has the identical high-speed PCI bus mastering, scatter-gather technology, and double buffering. This leading technology delivers over 120 MB/second sustained transfers to system memory. Such high performance requires minimal CPU intervention so that it is free to work on other tasks or process the incoming data immediately. Consecutive video images are transferred in real-time to system memory enabling real-time video streaming applications, such as cine loop cardiology, to utilize the power of the I-Series. Real-time streaming to disk is also supported with appropriate high performance disk drives. Real-time display is simultaneously enabled by real-time transfer of image data directly to display card memory over the PCI bus. I-Color also features independent, dual video paths. For example, this allows the simultaneous display of YUV 4:2:2 color video and the transfer of 8 bit monochrome video data for processing. A popular application for this feature is real-time metrology where users require color monitoring, but need high accuracy monochrome images for processing.

Video

I-Color supports up to four standard video inputs from a variety of cameras and medical input devices. The four inputs can be mixed between the following video input formats: composite color, S-Video, monochrome, NTSC, PAL, RS-170, and CCIR. For fine-tuning of the video signal, 8 bit brightness, contrast, hue, and saturation controls are available. Scaling and windowing of the video input are provided.

Controls

In addition to its leading performance and accuracy, I-Color provides the controls necessary for many imaging applications: a dedicated external trigger and camera power at +12 V DC.

Software

I-Color is supported by the IDEA™ (Imaging Development Environment for Applications) software development kit. By using IDEA, developers have the confidence of knowing that they can write their applications once and have support built-in for the entire I-Series (both current and future) and HI*DEF™ product families. Eliminated forever is the need to re-write software every time a new frame grabber related requirement arises or a new board is introduced. The software compatibility built into the architecture of IDEA allows the simple movement to other products in the I-Series or HI*DEF family. With IDEA, ActiveX controls are provided to facilitate easy development with Visual Basic, Visual C++, and Delphi. Extensive example programs (with source code) are provided with I-Color. Functions of the example programs include triggered acquisition, video streaming to AVI files, integration with Pegasus Imaging compression software for streaming, and overlays. For users with higher level application requirements, drivers are available for Common Vision Blox, Image-Pro Plus, Optimas, and TWAIN.

I-Color Specifications

I-Color Block Diagram

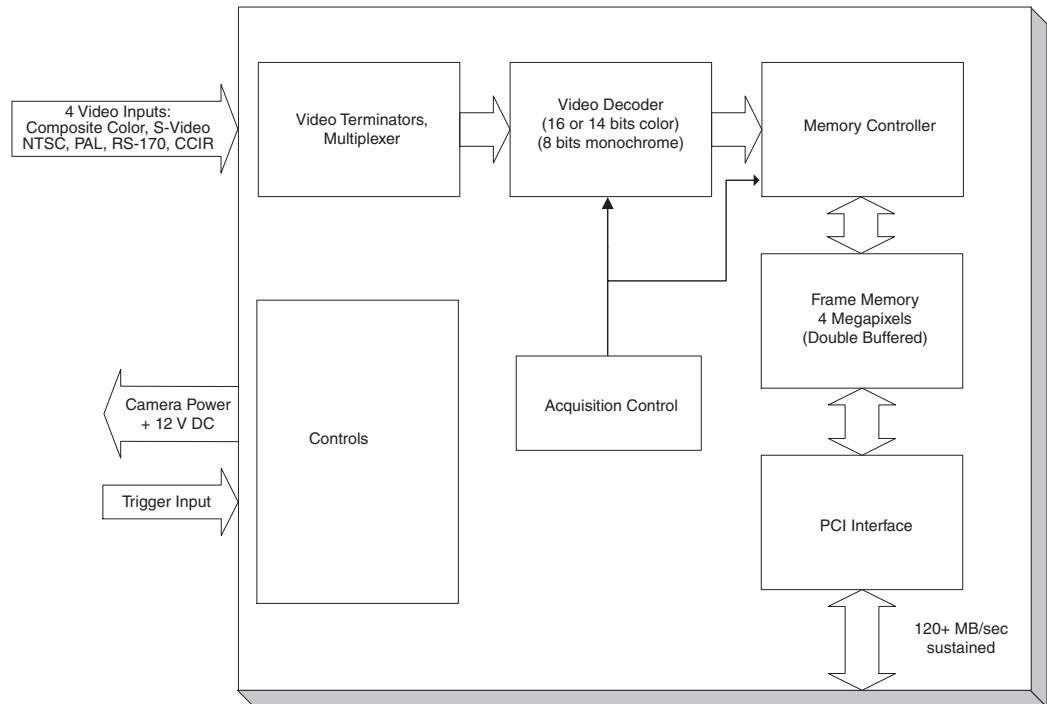

Video

- 4 video inputs (4 composite; 2 S-Video & 1 composite; or 1 S-Video & 3 composite)
- Composite video, S-Video, monochrome
- NTSC, PAL, RS-170, CCIR
- Standard video resolutions and frequencies
- VCR stabilization
- Real-time scaling and windowing
- AGC (on/off)
- Input range: 0.5 V pp to 2.0 V pp
- Offset: -1.0 V to 2.0 V DC
- 75 ohm termination
- Programmable brightness, contrast, hue, saturation; 8 bits each
- AC coupled with DC restoration
- Composite sync (analog or TTL)
- Bandwidth: 4 MHz
- Pixel resolution: up to 640 x 480 NTSC & RS-170; up to 768 x 576 PAL & CCIR

Image Quality

- Pixel jitter: ± 2.0 ns
- S/N ratio: 47 dB
- Linearity: Better than 99%
- A/D conversion: 16 or 24 bits color; 8 bits monochrome
- Color formats: YUV 4:2:2; RGB 8:8:8

Controls

- Dedicated trigger input
- Camera power: +12 V DC @ 1.0 A

Performance

- 120+ MB/second sustained to system memory via PCI bus master
- Real-time video streaming
- Real-time transfer to VGA memory
- Real-time transfer to industry-standard VGA boards via VIP/VMI over-the-top bus
- Storage memory: 4 Megapixels; double buffered

Physical

- Five-eighths size PCI card
- One female S-Video connector
- One female BNC connector
- One female 25 pin D-shell connector

Cabling

- Standard S-Video and BNC cables (user provided)
- I-Series general purpose cable (optional)
- I-Series multi-BNC cable (optional)

Software

- Windows 2000, 98, 95, NT
- Example application programs (source code included)
- Real-time video streaming with AVI file creation
- IDEA software development kit
- ActiveX controls
- Common Vision Blox, Image-Pro Plus, Optimas, and TWAIN drivers



978-458-4624

info@foresightimaging.com

www.foresightimaging.com